

Technical Data Sheet MATRIX

1. DESCRIPTION

Modular recycled polypropylene formwork for raised floors.

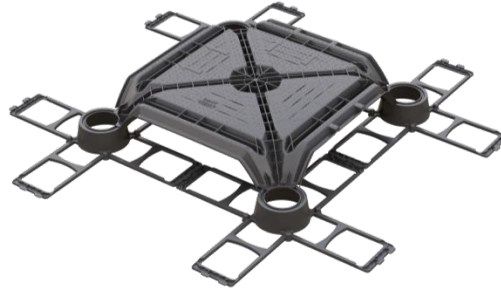

2. TECHNICAL SPECIFICATIONS

Material		Polypropylene recycled – Type GRAPLENE
Colour	-	Black
Formwork dimensions*	cm	58 x 58 x H9
Grid dimensions*	cm	58 x 58 x H6
Weight formwork / grid	kg	1,62 (± 15%) / 0,21 (± 15%)
Concrete consumption flush to the formwork**	m ³ /m ²	0,018
MEP passage	mm	1x Ø400mm x 60mm / 2x Ø300mm x 50mm
Laying time	m ² /h/worker	50
Production place	-	Italy

* With recycled material the measurements must be considered with a tolerance of ± 1.5%.

** Volume is subject to change depending on casting conditions and material tolerances

3. LOAD TABLE

LOAD (Kg/m ²)	FOUNDATION THICKNESS (cm)	REBAR (mm)
500	4	Ø6 / 20x20
1.000	5	Ø6 / 20x20
2.500	7	Ø8 / 20x20
5.000	8	Ø10 / 20x20
10.000	10	Ø12 / 20x20
>10.000	To be evaluated case by case by consulting the Geoplast technical office	

*It's designer's responsibility to assess that the laying plan is able to guarantee the pressures indicated.

TECHNICAL DRAWINGS

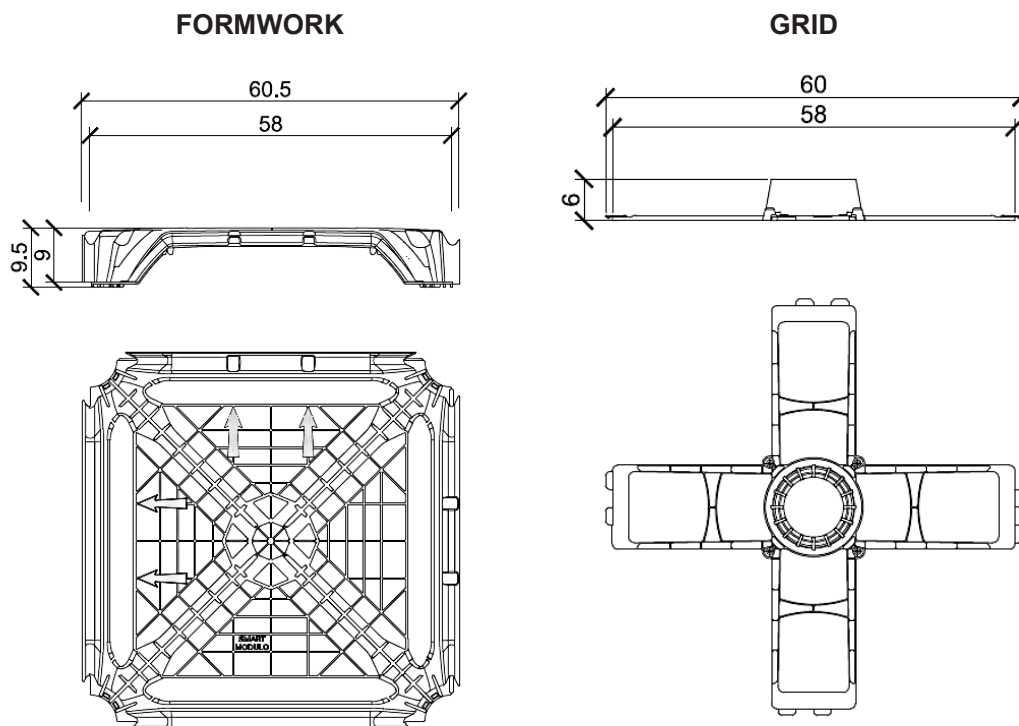

Section view – MEP Passage

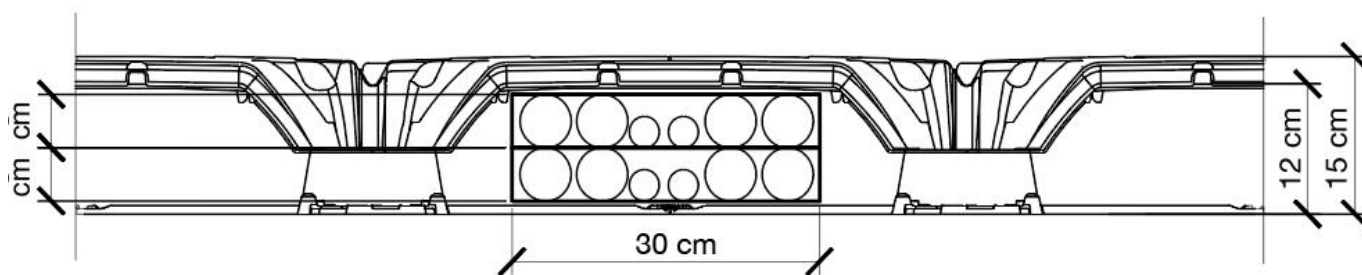

MEP passage	N°	Size
	1	Ø 40cm x 6cm
	2	Ø 30cm x 5cm

Matrix is laid down on the floor slab directly following the removal of any debris.

Matrix installation is carried out in 2 steps:

1. Arrange all the grids on the surface, making sure that they are hooked correctly.
2. Place the formworks from right to left and from top to bottom, always keeping the printed arrows up essential to check that the feet fit together correctly.

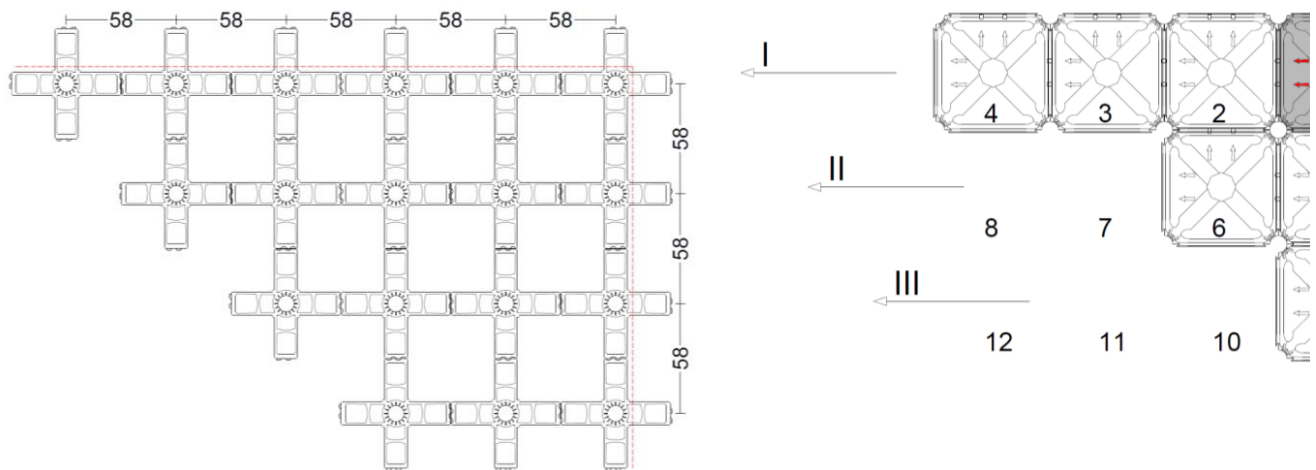

6. PACKAGING AND TRANSPORT

		FORMWORK	GRID
Product code	-	EMATRIX858	EBASMAT5858
Packaging	cm	122 x 122 x H253	100 x 140 x H253
Quanty per pallet	pcs	312	1135
Type of packaging	-	Stacked and wrapped in plastic film on pallet	Stacked and wrapped in plastic film on pallet
Package gross weight	kg	520	260