

MANDÍK[®]

PERFORATED SQUARE OUTLET DVCM

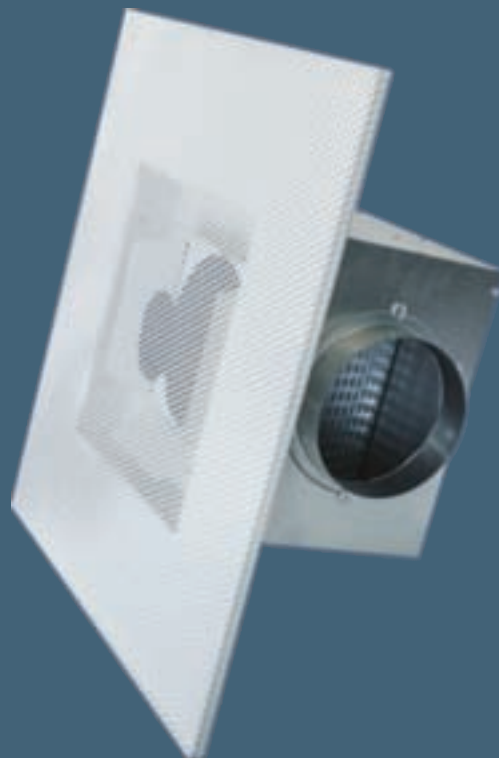

These technical specifications state a row of manufactured sizes and versions of whirling air outflow outlets DVCM (further only outlets). It is valid for production, designing, ordering, delivery, assembly and operation.

■ **CONTENT**

■ GENERAL	3
Description.....	3
Design.....	3
Installation.....	3
Dimensions and weights.....	4
■ TECHNICAL DATA	5
■ MATERIAL, FINISHING	6
Material and finishing.....	6
■ TRANSPORTATION AND STORAGE	7
Logistics terms.....	7
■ ORDERING KEY	7

■ GENERAL

Description

The DVCM perforated square outlet is a air-conditioning element suited for distributing cooled or heated air with a high temperature differential. It is suited for ventilating and air-conditioning of rooms, halls or department stores where the air supply through the ceiling is required.

Outlets are intended for environment protected against weather impacts with the classification of climatic conditions class 3K5, without condensation, frost, ice formation and without water even from other sources than rain according to EN 60 72133, change A2.

Temperature in the place of installation is permitted to range from - 20°C to +70°C.

Outlets are suitable for systems without abrasive, chemical and adhesive particles.

If is not noticed other way, all dimensions and weight are in millimeters and kilograms.

Design

The DVCM outlets are supplied with connection boxes or separately. They are designed for air supply or return air. The connection boxes are divided into horizontal or vertical connections.

The supply connection outlet is provided with a dispersion disk in the centre, allowing better dispersal of the supplied air in the space. The supply connection box is equipped with a dispersion plate and four blades to adjust the direction of the supplied air.

The return air outlets do not contain the dispersion disk and the discharge connection boxes do not contain the dispersion disk and blades.

The connection boxes can be supplied with a control valve in the supply branch (for design with horizontal connection only).

Supply connection box

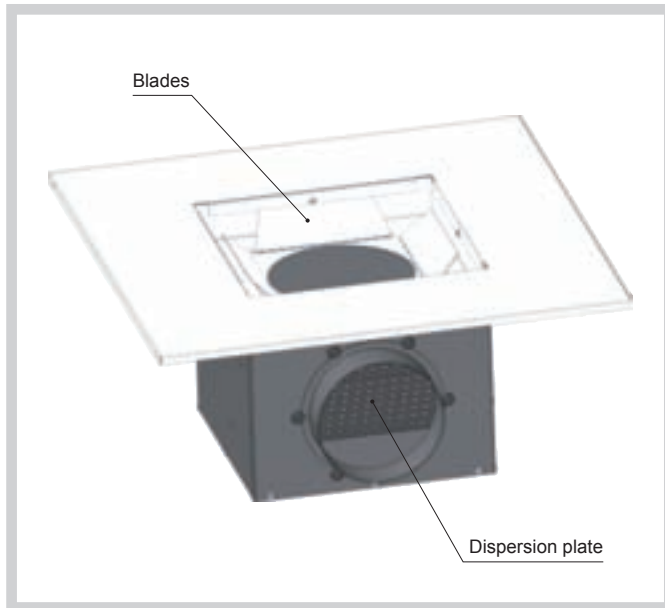

Return air connection box



Possible combinations of boxes and front panels

		Front panel design				
		300	400	500	600	625
Box design	250	YES	YES	YES	YES	YES
	300	x	YES	YES	YES	YES
	400	x	x	YES	YES	YES
	500	x	x	x	YES	YES
	550	x	x	x	YES	YES

Installation

Perforated air diffuser DVCM is designed for installation under ceiling in grid.

DVCM is designed for environments of weather protection Class 3K5 according to EN 60 721-3-3 and BNV spaces according to EN 1127-1.

Dimensions and weights

Horizontal connection box (supply air)

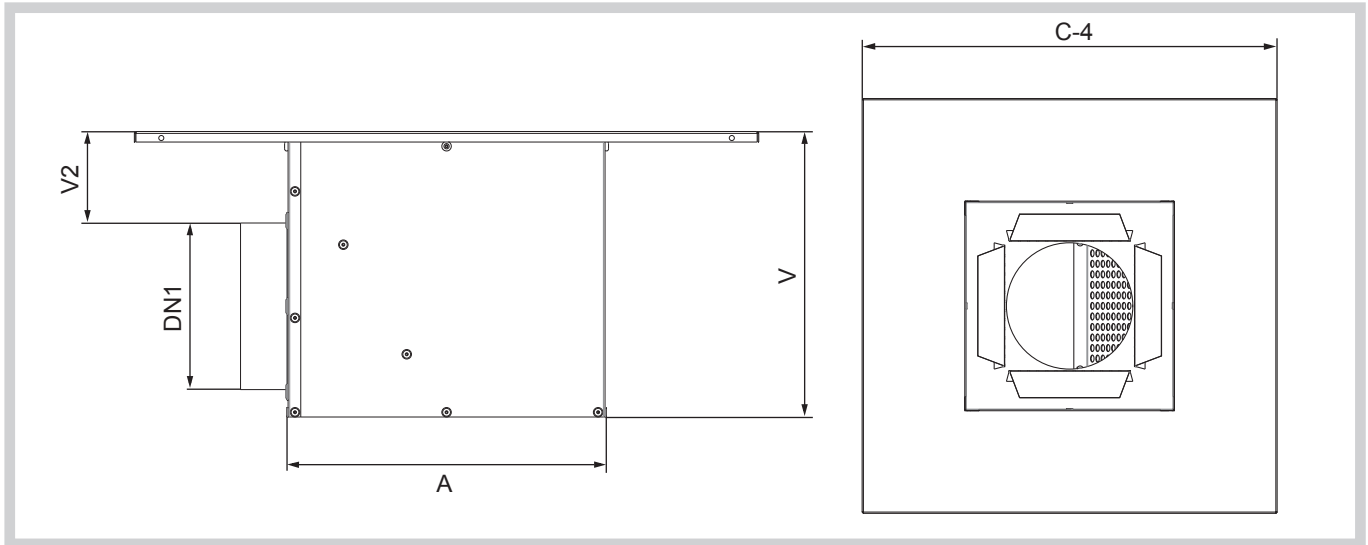

Front plate (supply air)

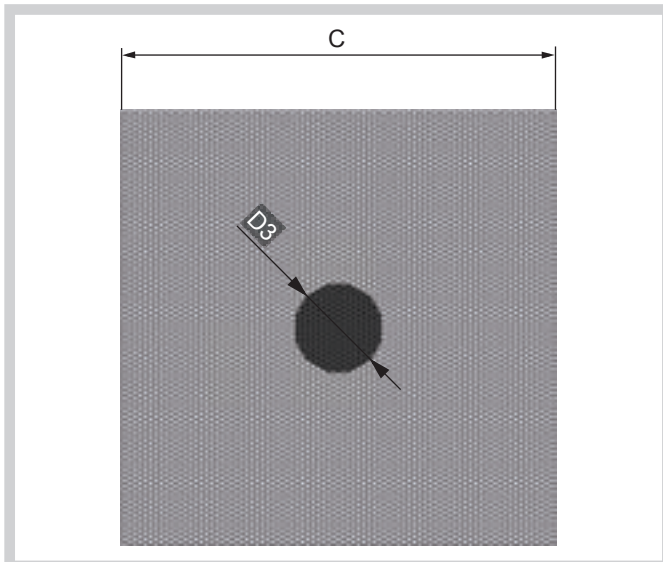

Vertical connection box

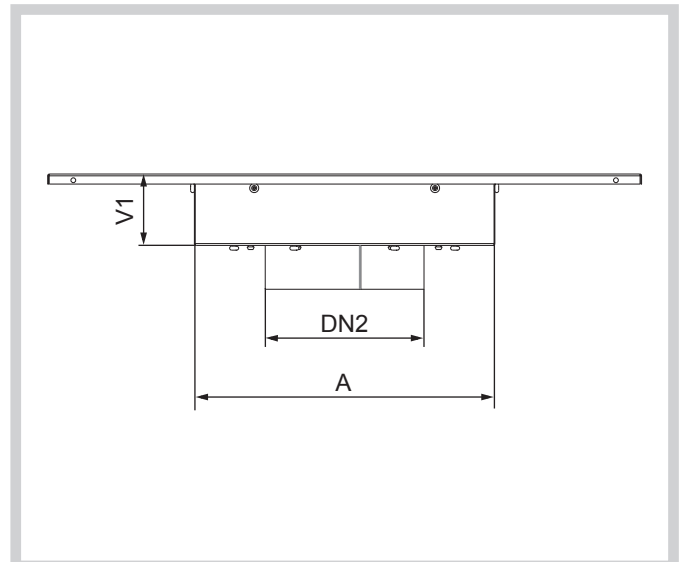

Table of dimensions

Box/ Front panel	A	V	DN1	V2	C	V1	DN2	D3
250/300	250	235	125	85	295	70	125	90
250/400	250	235	125	85	395	70	125	90
250/500	250	235	125	85	495	70	125	90
250/600	250	235	125	85	595	70	125	90
250/625	250	235	125	85	620	70	125	90
300/400	300	270	160	85	395	70	160	120
300/500	300	270	160	85	495	70	160	120
300/600	300	270	160	85	595	70	160	120
300/625	300	270	160	85	620	70	160	120
400/500	400	315	200	87,5	495	75	200	165
400/600	400	315	200	87,5	595	75	200	165
400/625	400	315	200	87,5	620	75	200	165
500/600	500	325	200	90	595	85	250	220
500/625	500	325	200	90	620	85	250	220
550/600	550	390	250	100	595	105	315	255
550/625	550	390	250	100	620	105	315	255

Table of boxes weights

Dimensions [mm]	Design			
	Horizontal air supply	Horizontal drainage	Vertical air supply	Vertical drainage
250	4,1	3,8	2,7	2,6
300	5,0	4,3	3,0	2,8
400	6,4	5,4	3,0	2,8
500	7,7	6,4	3,3	2,9
550	9,6	7,8	3,7	3,1

Table of front panels weights

Dimensions [mm]	300	400	500	600	625
Weights [kg]	0,4	0,7	1,0	1,5	1,6

■ TECHNICAL DATA

Supply design

Air volume		Design	Blades pattern														
			4-way			3-way			2-way opposite			2-way corner			1-way		
[m³/s]	[m³/h]		H	Pc	Lw	H	Pc	Lw	H	Pc	Lw	H	Pc	Lw	H	Pc	Lw
0,015	54	250	0,4	1	<2	0,4	1	<2	0,6	2	2	0,6	3	4	0,9	7	12
0,020	72	250	0,6	1	4	0,6	2	6	0,7	4	9	0,7	4	11	1,2	12	20
0,025	90	250	0,7	2	10	0,7	3	12	0,9	5	15	0,9	7	17	1,5	19	25
		300	0,6	1	<2	0,6	1	3	0,8	3	6	0,8	3	18	1,3	9	18
0,030	108	250	0,8	3	15	0,9	4	17	1,1	8	20	1,1	10	22	2	28	29
		300	0,7	1	<2	0,7	2	7	0,9	4	11	0,9	5	13	1,5	13	21
0,040	144	250	1,1	4	21	1,2	6	24	1,5	13	26	1,5	17	27	2,5	49	37
		300	0,9	3	13	1	3	15	1,2	6	18	1,2	8	20	2	23	29
		400	0,8	1	5	0,8	2	7	1	3	11	1	4	11	1,7	11	21
0,050	180	250	1,4	6	27	1,5	10	29	1,9	20	32	1,9	25	32	-	-	-
		300	1,2	4	18	1,2	5	20	1,5	10	24	1,5	13	25	2,5	34	34
		400	1	2	11	1	3	13	1,3	5	16	1,3	6	17	2,1	17	26
0,060	216	250	1,7	8	32	1,8	13	36	2,2	28	37	2,2	35	39	-	-	-
		300	1,5	6	23	1,5	8	24	1,8	14	28	1,8	19	30	3	51	39
		400	1,1	3	16	1,3	4	18	1,5	7	20	1,5	8	22	2,5	24	30
		500	-	-	-	-	-	-	-	-	-	-	-	-	-	2,1	13
0,080	288	300	1,8	11	30	1,9	14	32	2,4	26	35	2,4	33	37	-	-	-
		400	1,5	6	22	1,7	7	23	2	13	27	2	15	28	3,4	43	38
		500	1,3	4	16	1,4	5	17	1,8	8	20	1,8	10	23	2,8	23	30
		550	-	-	-	-	-	-	-	-	-	-	-	-	-	2,4	13
0,100	360	300	2,3	17	36	2,4	21	38	-	-	-	-	-	-	-	-	-
		400	1,9	9	28	2,1	11	30	2,6	20	30	2,6	23	34	-	-	-
		500	1,6	4	21	1,8	8	23	2,2	12	26	2,2	15	28	3,5	35	36
		550	1,4	4	15	1,6	4	18	1,9	7	20	1,9	8	22	3,1	21	30
0,125	450	400	2,4	13	34	2,6	18	34	-	-	-	-	-	-	-	-	-
		500	2	10	26	2,3	12	28	2,8	19	32	2,8	23	34	-	-	-
		550	1,8	6	21	2	7	23	2,4	10	25	2,4	13	27	3,8	32	36
0,150	540	400	2,9	19	38	-	-	-	-	-	-	-	-	-	-	-	-
		500	2,5	15	32	2,7	17	33	3,4	28	36	3,4	34	39	-	-	-
		550	2,2	8	25	2,4	10	27	2,9	15	30	2,9	19	32	4,6	47	41
0,200	720	500	3,3	25	38	3,6	30	41	-	-	-	-	-	-	-	-	-
		550	2,9	14	32	3,2	18	35	3	27	38	3	33	39	-	-	-
0,250	900	550	3,6	22	38	4	27	40	4,9	42	43	4,9	50	44	-	-	-
0,300	1080	550	4,3	32	42	-	-	-	-	-	-	-	-	-	-	-	-

H [m] - airflow range

Pc [Pa] - pressure loss

Lw [dB(A)] - acoustic power level (Sound data based on assumed sounddampening of the room of 10dB)

☐ - we do not recommend this setting of blades!

Blades pattern

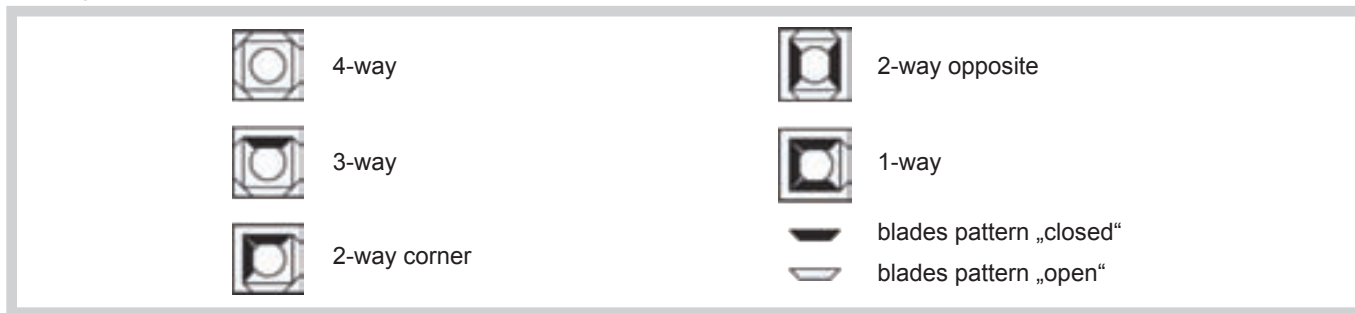

Return air design

Air volume		Design	Pressure loss Pc [Pa]	Sound power level Lw [dB(A)]
V [m³/s]	V [m³/h]			
0,015	54	250	1	≤ 12
0,020	72	250	3	≤ 12
0,025	90	250	4	≤ 12
		300	1	≤ 12
0,030	108	250	6	≤ 12
		300	2	≤ 12
0,040	144	250	11	≤ 12
		300	4	≤ 12
		400	1	≤ 12
0,050	180	250	16	≤ 12
		300	6	≤ 12
		400	2	≤ 12
0,060	216	250	24	17
		300	9	≤ 12
		400	3	≤ 12
		500	3	≤ 12
0,080	288	300	15	13
		400	6	≤ 12
		500	5	≤ 12
		550	3	≤ 12
0,100	360	300	24	19
		400	9	≤ 12
		500	8	≤ 12
		550	4	≤ 12
0,125	450	400	14	15
		500	12	15
		550	6	≤ 12
0,150	540	400	21	20
		500	18	20
		550	9	10
0,200	720	500	31	27
		550	16	17
0,250	900	550	25	23
0,300	1080	550	35	28

MATERIAL, FINISHING

Material and finishing

Front panels are made of steel sheet. The surface is coated with white baking varnish, shade number RAL 9010. Vanes for regulation of air flow distribution are supplied in black as a standard. The vanes can be supplied in white, if this requirement is mentioned with the order. Requirements for other shades of front panels have to be agreed with the manufacturer in advance. The connection boxes are made of galvanized steel sheet.

■ **TRANSPORTATION AND STORAGE**

Logistic terms

The outlets are delivered in cardboard packaging. They are transported in bulk by common means of transport. If agreed with the customer, the outlets can be delivered on pallets. When handling during transport or storage, the outlets must be protected against mechanical damage and weather effects.

If not otherwise agreed, the handover is considered when the goods is forwarded to the carrier.

The outlets must be stored in closed rooms, in environment without aggressive vapours, gases and dust. The temperature in the rooms must be maintained from -5 to +40°C and relative humidity max. 80%.

■ **ORDERING KEY**

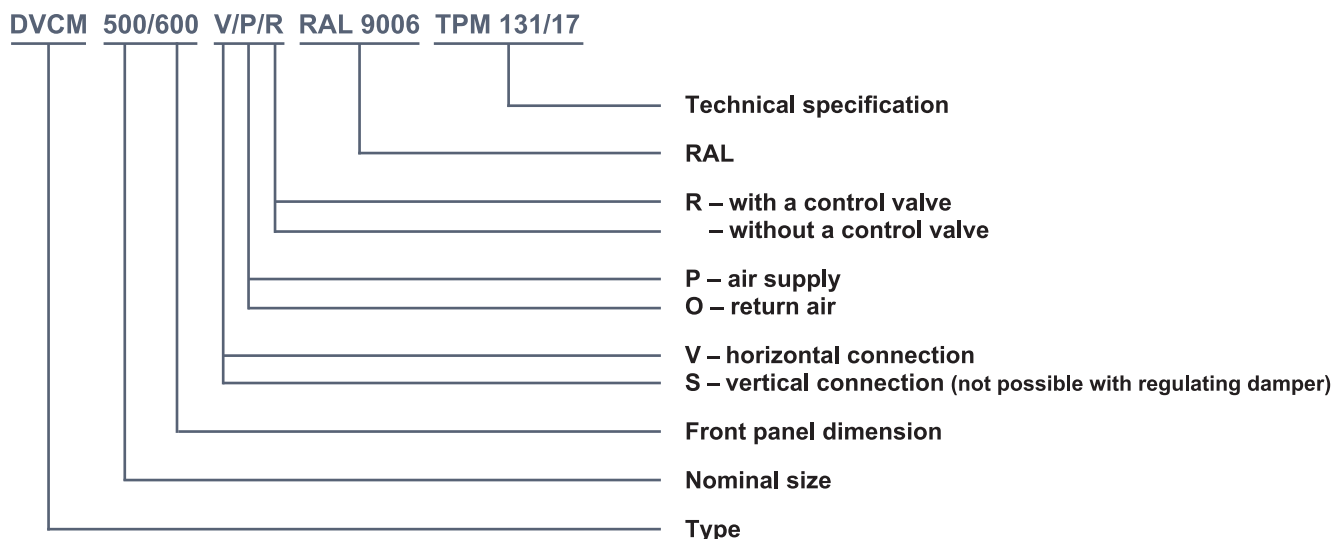

MANDÍK, a.s.
Dobříšská 550
26724 Hostomice
Czech Republic
Tel.: +420 311 706 706
E-Mail: mandik@mandik.cz
www.mandik.com

The producer reserves the right for innovations of the product. For actual product information see
www.mandik.com